



Pendant Incandescent



Pendant Fluorescent



Ceiling Incandescent



Ceiling Fluorescent

NEW!

For original NV Series see PDF cat. page L2A at www.hubbell-killark.com

Class I, Div. 2, Groups A,B,C,D
Class I, Zone 2, Groups IIC, IIB, IIA
Class II, Div. 2, Groups F,G
Class III
Marine
NEMA 3, 4, 4X, IP66

Certified - File LR11713

ABS Type Approval

FEATURES-SPECIFICATIONS

ENVIRORITE® II

Applications

Designed specifically for corrosive & wet NEMA 4X and hazardous environments. Typical applications include manufacturing plants, chemical and petrochemical processing facilities, sewage treatment plants, off-shore and dockside installations, agricultural, commercial/industrial, mining and marine facilities.

Features

- NV2 Series non-metallic light fixtures combine an outstanding balance of strength, stiffness, toughness and electrical properties
- Energy and labor saving fluorescent or incandescent models
- Accessories include polycarbonate dome reflectors and wall extension
- Molded from 30% glass-filled thermoset polyester for high strength
- Resists corrosive effects of most chemicals, hydrocarbons and solvents
- Designed for indoor and outdoor applications.

to the following standards:

- UL 1598 Standard for luminaires
- UL 1598A Marine type luminaires
- UL 844 Standard for lighting fixtures for hazardous locations
- CSA C22.2 no. 137-M1981 electric luminaires for use in hazardous locations
- Enclosed and gasketed
- NEMA 3, 4X, IP66

Pendant 3/4" Fixture w/clear Globe & Guard*		
Type	Standard Globe	Tempered Globe
150A Incan.	NV2IG15ASG	NV2IG15AHG
13 W Fluor.	NV2FG13ASG	NV2FG13AHG
18 W Fluor.	NV2FG18ASG	NV2FG18AHG
26 W Fluor.	NV2FG26ASG	NV2FG26AHG
32 W Fluor.	NV2FG32ASG	NV2FG32AHG
42 W Fluor.	NV2FG42ASG	NV2FG42AHG

Ceiling 3/4" Fixture w/clear Globe & Guard*		
Type	Standard Globe	Tempered Globe
150A Incan.	NV2IG15XSG	NV2IG15XHG
13 W Fluor.	NV2FG13XSG	NV2FG13XHG
18 W Fluor.	NV2FG18XSG	NV2FG18XHG
26 W Fluor.	NV2FG26XSG	NV2FG26XHG
32 W Fluor.	NV2FG32XSG	NV2FG32XHG
42 W Fluor.	NV2FG42XSG	NV2FG42XHG

Wall 3/4" Fixture w/clear Globe & Guard*		
Type	Standard Globe	Tempered Globe
150A Incan.	NV2IG15BSG	NV2IG15BHG
13 W Fluor.	NV2FG13BSG	NV2FG13BHG
18 W Fluor.	NV2FG18BSG	NV2FG18BHG
26 W Fluor.	NV2FG26BSG	NV2FG26BHG
32 W Fluor.	NV2FG32BSG	NV2FG32BHG
42 W Fluor.	NV2FG42BSG	NV2FG42BHG

***Notes:**

- Tempered Globes are required for Wet Location applications
- All assemblies are unit packed with required components (not assembled)
- **Fluorescent unit pack models (only) include the lamp**
- Reflector is sold separately. For wall mounting with reflector, the NVEXTG extension is required and sold separately
- Fluorescent models use "world voltage" ballasts for 120VAC through 277VAC 50/60Hz applications
- Incandescent models 277VAC max.
- For M20 ceiling units change "X" in part # to "M". For wall units change "B" to "W". M20 Pendant not available.

Colored Globe Options**

Example: NV2IG15ASG-R for Ruby Standard Globe or NV2IG15AHG-R for Ruby Tempered Globe

Suffix and available combinations		
Color	Standard Globe	Tempered Globe
Amber	A	A
Blue	B	B
Ruby	R	R
Green	G	NA
Purple	P	NA
Blue-Green	BG	BG

**Tempered globes are required for wet locations.

T-codes @ 40°C Max; with or without Reflector

Globe Type	Class I Clear	Div.2 Color	Class II Clear	Div.2 Color	Minimum Start	
					°C	°F
75A	T2C	T2B	T3C	-	-	-
100A	T2A	T2	T3C	-	-	-
150A	T2B	T2	-	-	-	-
13 Fluor	T3C	T3C	T4A	T4A	-15	5
18 Fluor	T3C	T3C	T4A	T4A	-15	5
26 Fluor	T3B	T3A	T4A	T4A	-15	5
32 Fluor	T3B	T3A	T4A	T4A	-15	5
42 Fluor	T2D	T2C	T4A	T4A	-15	5

Min. supply wire Fluor. 60°C, Incan. 90°C

Fluorescent Operating Max. Amps		
Type	120 VAC	277 VAC
13W Fluor	.144	.067
18W Fluor	.158	.073
26W Fluor	.22	.097
32W Fluor	.285	.128
42W Fluor	.38	.166



Wall Mount
Incandescent



Wall Mount
Fluorescent



Wall Mount with
Extension and Dome
Reflector accessories

NEW!

Class I, Div. 2, Groups A,B,C,D
 Class I, Zone 2, Groups IIC,IIB,IIA
 Class II, Div. 2, Groups F,G
 Class III
 Marine
 NEMA 3, 4, 4X, IP66

Certified - File LR11713

ABS Type Approval

COMPONENT PARTS

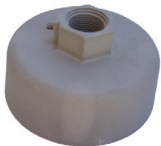

Pendent



Ceiling/Wall

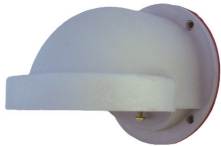

Wall Elbow



Ceiling/Wall
(Interior Detail)



Incandescent



Fluorescent



Globe



Guard



Reflector



Extension



Gray Blank



Clear

NV2 SPLICE BOXES - INCLUDES SILICONE GASKETS & BRASS SCREWS			
CATALOG NUMBER	DESCRIPTION		
NV2AG	Pendent	3/4" NPT	Pendent splice box includes a 316 stainless steel set screw at the conduit connection
NV2XG ^①	Ceiling Box	3/4" NPT	Ceiling box vol. 24 cu. inches
NV2MG ^①		M20	
NV2BG	Wall Bracket		Use with NV2XG or NV2MG for wall mount

NV2 BODIES	
CATALOG NUMBER	DESCRIPTION
NV2IG15	Incandescent Body with E-26 medium base socket; fixture rated voltage 277VAC max.
NV2FG13	13 W Fluorescent Body World Voltage 120V - 277V 50/60Hz
NV2FG18	18 W Fluorescent Body World Voltage 120V - 277V 50/60Hz
NV2FG26	26 W Fluorescent Body World Voltage 120V - 277V 50/60Hz
NV2FG32	32 W Fluorescent Body World Voltage 120V - 277V 50/60Hz
NV2FG42	42 W Fluorescent Body World Voltage 120V - 277V 50/60Hz

NV2 GLASS GLOBES & GUARDS ^②		
CATALOG NUMBER	DESCRIPTION	
VCG-100	Clear	150 watt Lamp size A-21 max.
VCGP-100	Clear, Tempered	
NV2GG	Guard	

NV2 REFLECTORS AND EXTENSION	
CATALOG NUMBER	DESCRIPTION
NVPSD12	White Polycarbonate Reflector (secured by guard)
NVEXTG	Extension (for wall mount fixture with reflector)

BLANK COVERS FOR NV2XG CEILING BOXES	
CATALOG NUMBER	DESCRIPTION
NV2CG	Gray Cover
NV2CC ^①	Clear Cover

NV2F FLUORESCENT REPLACEMENT LAMPS AND BALLASTS		
MQL13	13 W Quad-Pin Lamp 900 Lumens	BKF131830 13/18 Watt Rep. Ballast
MQL18	18 W Quad-Pin Lamp 1200 Lumens	
MQL26	26 W Quad-Pin Lamp 1800 Lumens	BKF263230 26/32 Watt Rep. Ballast
MQL32	32 W Quad-Pin Lamp 2400 Lumens	
MQL42	42 W Quad-Pin Lamp 3200 Lumens	BKF324230 32/42 Watt Rep. Ballast

^① NV2 ceiling (wall) boxes have 4 10-32 brass inserts with 2 ground screws. May be used for wet locations, as terminal/junction, boxes, or instruments using 'clear' blank cover.
^② See page L12 for colored globes; use tempered for wet locations.



Dimensions*

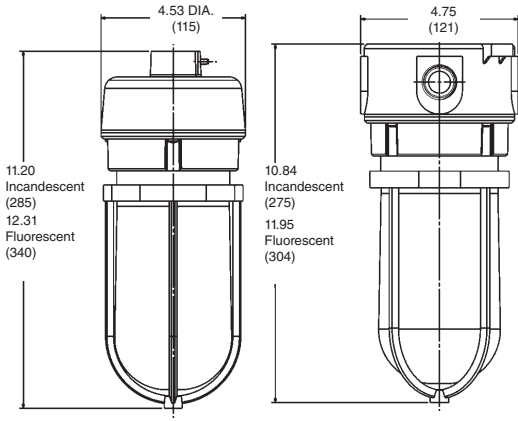

Pendant

Ceiling

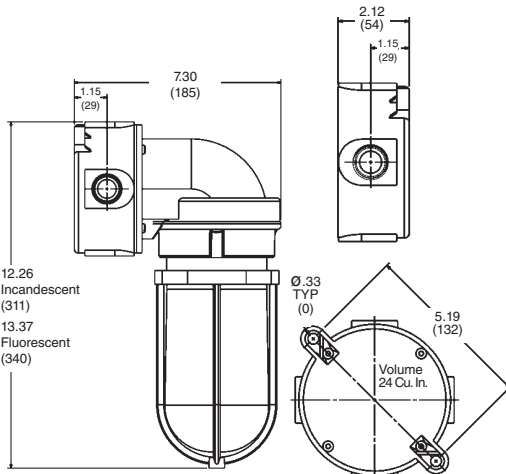

Wall

NV2XG

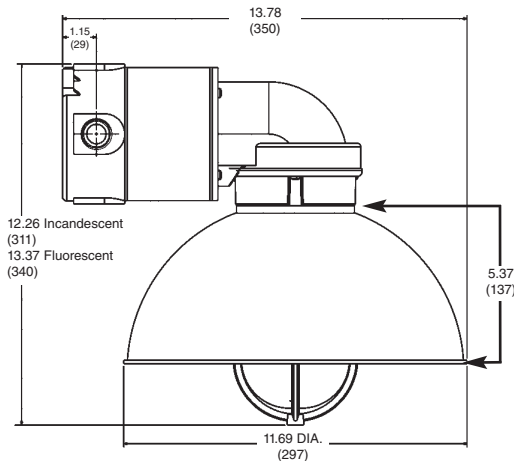

Wall mount with optional reflector and with extension. Extension required only for wall mount units using reflector.

*NOTE: Dimensional diagrams show incandescent models, but include height also for fluorescent.

NV To NV2 Cross Reference

OLD	NEW#	NEW DESCRIPTION
Complete Fixtures		
NVA15GG	NV2IG15ASG	INC 150W PEND STD GLOBE/GRD
NVA15GHG	NV2IG15AHG	INC 150W PEND TEMPER GLB/GRD
NVX15GG	NV2IG15XSG	INC 150W CEIL STD GLOBE/GRD
NVX15GHG	NV2IG15XHG	INC 150W CEIL TEMPER GLB/GRD
NVB15GG	NV2IG15BSG	INC 150W WALL STD GLOBE/GRD
NVB15GHG	NV2IG15BHG	INC 150W WALL TEMPER GLB/GRD
NVQA18GG	NV2FG18ASG	FL18 120-277 PEND STD GLOB/GRD
NVQA18GHG	NV2FG18AHG	FL18 120-277 PEND TEM GLOB/GRD
NVQX18GG	NV2FG18XSG	FL18 120-277 CEIL STD GLOB/GRD
NVQX18GHG	NV2FG18XHG	FL18 120-277 CEIL TEM GLB/GRD
NVQB18GG	NV2FG18BSG	FL18 120-277 WALL STD GLOB/GRD
NVQB18GHG	NV2FG18BHG	FL18 120-277 WALL TEM GLOB/GRD

Components

NVA	NV2AG	3/4" Pendant
NVX	NV2XG	3/4" Ceiling (Wall) Box
NVB	NV2BG	Elbow, use with Ceiling Box
NVQFC	NV2FG18	Fluorescent Body 120-277VAC 50/60Hz
NVQFC184 (1)	NV2FG18	Fluorescent Body 120-277VAC 50/60Hz
NVFC	NV2IG15	Incandescent Body
NVFC-LT (2)	NV2IG15	Incandescent Body
NVG	NV2GG	Guard
NVQ-18	MQL18	18W Compact Fluor. Lamp
NVBC	NV2CG	Blank Cover w/Two Gaskets
NVSG	NV2CG	Use Blank Cover's extra gasket

- (1) "4" for 277VAC Fluorescent no longer required
- (2) Insulated socket incandescent no longer needed for 90c wire

Key New Features:

- Certified for Hostile Locations: Class I Div 2; Class II Div 2; N4X; IP66
- ABS Approval
- 120-277VAC 50/60Hz World Voltage Ballasts on Fluorescents
- Four new Fluorescent Wattages: 13, 26, 32, 42
- Only 90° C wire for Incandescent suitable for Marine with 150A
- New Dome Reflector
- Colored "100" Series globes can be ordered in assemblies
- M20 Metric ceiling/wall box
- Four 10-32 bosses in ceiling box for user applications
- Clear Blank covers available for user applications

Backward Compatibility:

- NVG & NV2GG are interchangeable
- Globes are interchangeable
- Old NV Incandescent and Fluorescent bodies will fit new NV2 Boxes and Elbow, but assembly is Wet Location listed only
- New NV2IG15 Incandescent will fit old NV Boxes and Elbow
- New NV2FGx Fluorescent will fit old NVX box, not pendant or elbow
- Reflectors will fit old bodies for pendant or ceiling applications

Photometrics

NV2IG15 Incandescent
With Globe & Guard
Candlepower - 150 Watt
A-21 lamp 2850 lumens
For 75 Watt multiply by .42
For 100 Watt multiply by .61

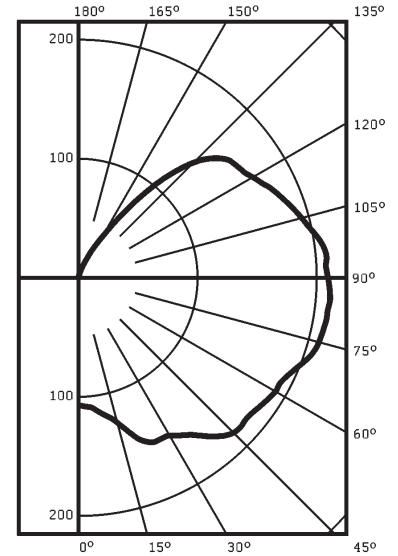
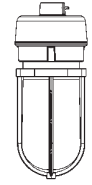

ZONE	LUMEN	LUMENS	%LAMP	%FIXT
0- 30	117	4.1	5.6	
0- 40	219	7.7	10.5	
0- 60	528	18.5	25.3	
0- 90	1172	41.1	56.1	
90-120	608	21.3	29.1	
90-130	754	26.5	36.1	
90-150	903	31.7	43.3	
90-180	915	32.1	43.9	
0-180	2087	73.2	100.0	

TOTAL LUMINAIRE EFFICIENCY = 73.2 %

COEFFICIENTS OF UTILIZATION - ZONAL CAVITY METHOD

% EFFECTIVE FLOOR CAVITY REFLECTANCE 0.20	80	70	50	30	10	0
% WALL REFLECTANCE 1w	70 50 30 10	70 50 30 10	50 30 10	50 30 10	50 30 10	0
ROOM CAVITY RATIO RCRW	20% Effective Floor Cavity Reflectance					
0	79.79	79.79	74.74	74.74	64.64	64.64
1	69.64	59.55	63.59	55.51	50.47	44.41
2	61.53	47.42	56.49	44.39	41.37	33.34
3	55.46	39.33	50.42	36.31	35.30	26.29
4	49.40	33.27	45.37	30.25	31.26	21.18
5	45.35	28.23	41.23	26.21	27.22	18.16
6	41.31	24.19	38.22	22.18	24.19	15.12
7	38.28	21.16	35.20	19.15	22.17	13.11
8	35.25	19.14	32.17	17.13	20.15	11.09
9	33.23	17.12	30.15	15.12	18.13	10.09
10	30.21	15.11	28.14	14.10	16.12	09.08

SPACING CRITERION = 2.3

TEST NO. 1716



